

## H2L Harsh Environment High Bay High to Low Temperature LED Luminaire



Available

### DESCRIPTION

The H2L combined the latest high efficiency and driver-less LED technology, the H2L delivers up to 40,500 lumens in an environment temperature of 239 °F (115° C ). Lumen adjust algorithm addresses the lumen drop issue with many high environment temperature LED applications.

### APPLICATIONS

Paper Mills, Steel Mills, Glass Factories, Overhead Cranes and other harsh industrial environments

### FEATURES

- AC LED driver Eliminate the need for Electrolytic Capacitors
- LED module is LM80 tested to 293° F (145° C )
- Patent pending lumen adjust algorithm
- High temperature tolerant COB technology
- No remote LED driver
- No active cooling
- Operating temperature from -112° F to 239° F (-80° C to 115° C)
- Fixture voltages are 120V, 277V, 347V and 480V
- Surge protection 6KV
- Power factor > 0.9
- Over 40,000 lumen output with efficacy up to 118 LPW
- Multiple mounting options
- UL/cUL listed for wet location
- IP 66
- FCC

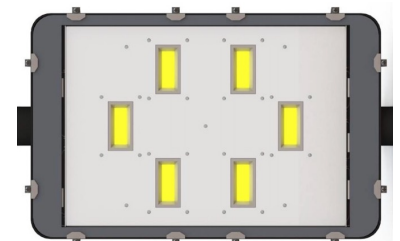

# PERFORMANCE DATA

Model Number	Input Voltage (Vac)	Wattage (W)	Current (A)	Lumen	CRI
H2L-350-XXK-120	120	350	2.9	40,500	80
H2L-350-XXK-277	277	350	1.3	40,500	80
H2L-350-XXK-347	347	350	1.0	40,500	80
H2L-350-XXK-480	480	350	0.7	40,500	80
H2L-210-XXK-120	120	210	1.8	24,300	80
H2L-210-XXK-277	277	210	0.8	24,300	80
H2L-210-XXK-347	347	210	0.6	24,300	80
H2L-210-XXK-480	480	210	0.4	24,300	80

## ORDERING GUIDE

Series	Wattage	CCT	Input Voltage
H2L	350 350W	50K 5000K	120 120Vac
	210 210W		277 277Vac
			347 347Vac
			480 480Vac

**Note:** Fixture is input voltage specific

## DIMENSIONS

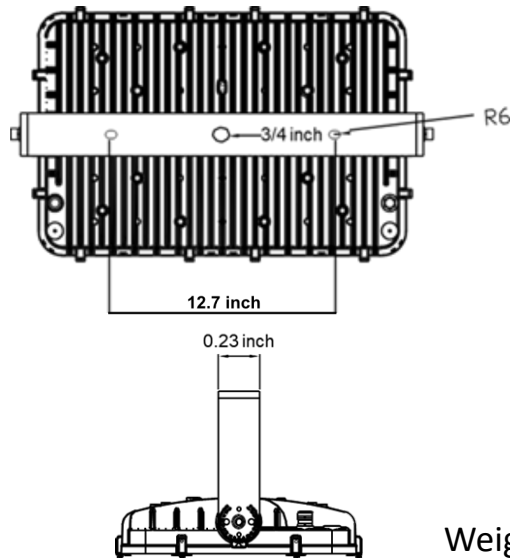
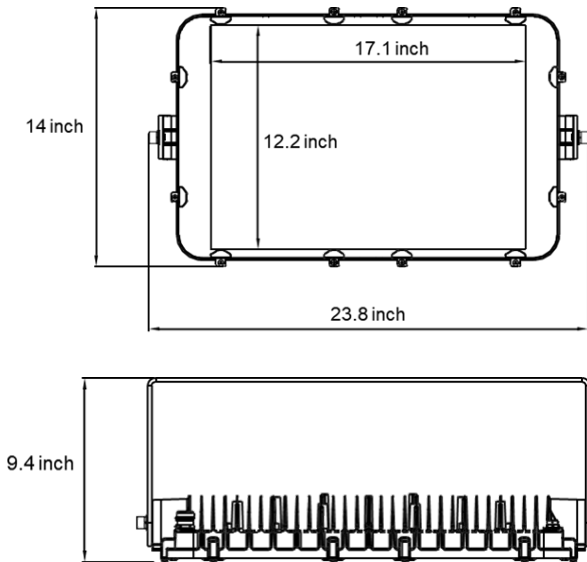

Weight: 28lb

## PHOTOMETRICS

