

INSTALLATION INSTRUCTIONS

ABS™ SERIES

LED WALLPACK

INSTALLATION AND SERVICE INSTRUCTIONS

AWP-5K-37W/ AWP-5K-56W/ AWP-5K-93W

SAFETY PRECAUTION :

IMPORTANT: READ CAREFULLY BEFORE INSTALLING FIXTURE. RETAIN FOR FUTURE REFERENCE.

GENERAL: Upon receipt the fixture, thoroughly inspect for any freight damage which should be brought to the attention of the delivery carrier. Compare the catalog description listed on the packing slip with the fixture label on the housing to assure you have received the correct material.

SAFETY: This fixture must be wired in accordance with the National Electrical Code and any applicable local codes and ordinances. Proper grounding is required to insure personal safety. Carefully observe the correct grounding procedure under installation section.

WARNING: Risk of Fire/Shock. To be installed by a licensed electrician only. Risk of Electrical Shock. Disconnect Power at circuit breaker panel before installing or servicing.

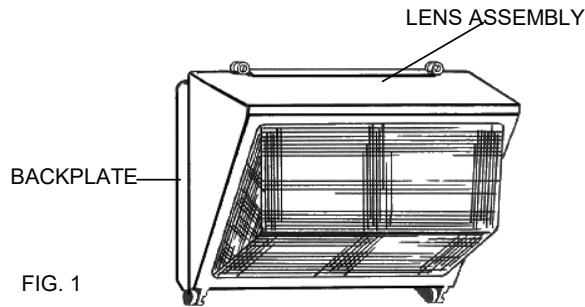

FIG. 1

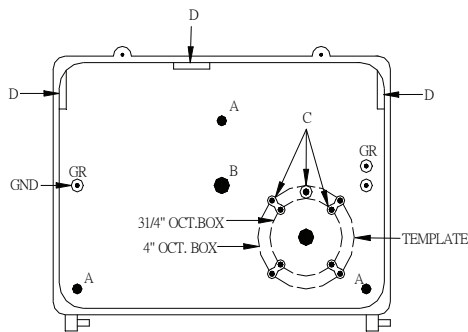

FIG.2

INSTALLATION :

1. Open the fixture by loosening the two screws on the side and remove the lens assembly. Remove the LED module and driver module from the backplate to clear the mounting space (may not apply to all models).
2. Prepare the back plate for mounting by drilling or knocking out the appropriate holes. (See Fig. 2).
3. Line up the back plate in the desired location and mount securely. Two gaskets are provided for a weather-tight seal between the template and the junction box.
4. If using electrical conduit, remove the screw cap from the desired conduit hole and replace with conduit. Route the branch circuit wires inside the fixture. If using a junction box, bring the branch circuit wires through the rear hole into the fixture.
5. Splice the branch circuit power leads to the fixture power leads, black to black (hot), white to white (neutral), and green to green (ground).
6. Reattach the LED module and driver module to the back plate.
7. Replace the lens assembly using the provided tamper-proof screws.

MOUNTING :

The back plate has a cast-in-place drill and knock-out template to match any standard recessed junction box, three 5/16" knockouts for mounting holes A and three 1/2" NPS tapped holes D for surface conduit, photocontrol.

- A – 5/16" dia. Knockouts
- B – 9/16" dia. Knockouts.
- C – Knockouts for #10 screw.
- D – 1/2" NPS tapped holes.

IMPORTANT:

To weather-proof your outdoor installation, be sure to seal all holes in fixture housing. (mounting, conduit, plugs, photocontrols, etc.) with silicone sealant.

REPLACING LED MODULE :

CAUTION - DISCONNECT ELECTRICAL CIRCUIT BEFORE REPLACING LAMP.

1. Release the screws and open the door frame.
2. Replace with the LED Module.
3. Close the door frame by tightening the screws.

TROUBLE SHOOTING CHECK LIST : If the light does not work.

Check your power source.

Check electrical connections.